

LANDA



■ **ibis**
450.075 all
pagg. 70-71



■ **ibis**
450.075 all
pagg. 70-71



■ **ibis**
450.00 nhg
pagg. 70-71
project by Visiolux - CH

■ **ibis**
450K075
pagg. 70-71
project by JCC Lighting - UK



■ **ibis**
450.075 all
pagg. 70-71



■ **ibis**
450.050 all
pagg. 70-71





■ **ibis**
450.075 nhg
pagg. 70-71
project by Ansell lighting - UK

serie/series

ibis

NEW



example code:

art.	electrification	finishing	size	colour
450	F18	.	00	nhg

COUNTRY example code:

art.	electrification	finishing	size	colour
450	F18	K	00	nhg

art.
450

design **aDD & Leon & Monte**

progetto **Meta-Distrettuale Numa**

OHIM:
patent No.
000346366-0001

corpo **alluminio pressofuso e estruso**
body in die casting and extruded aluminium
corps **en aluminium moulé sous pression et extrudé**
cuerpo aluminio inyectado y extrusionado
Körper **aus Aluminium-Druckguss**

diffusore **polycarbonato trasparente**
diffuser transparent polycarbonate
diffuser **polycarbonate transparent**
difusor polycarbonato transparente
Diffuser **Polykarbonat klar**

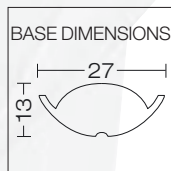
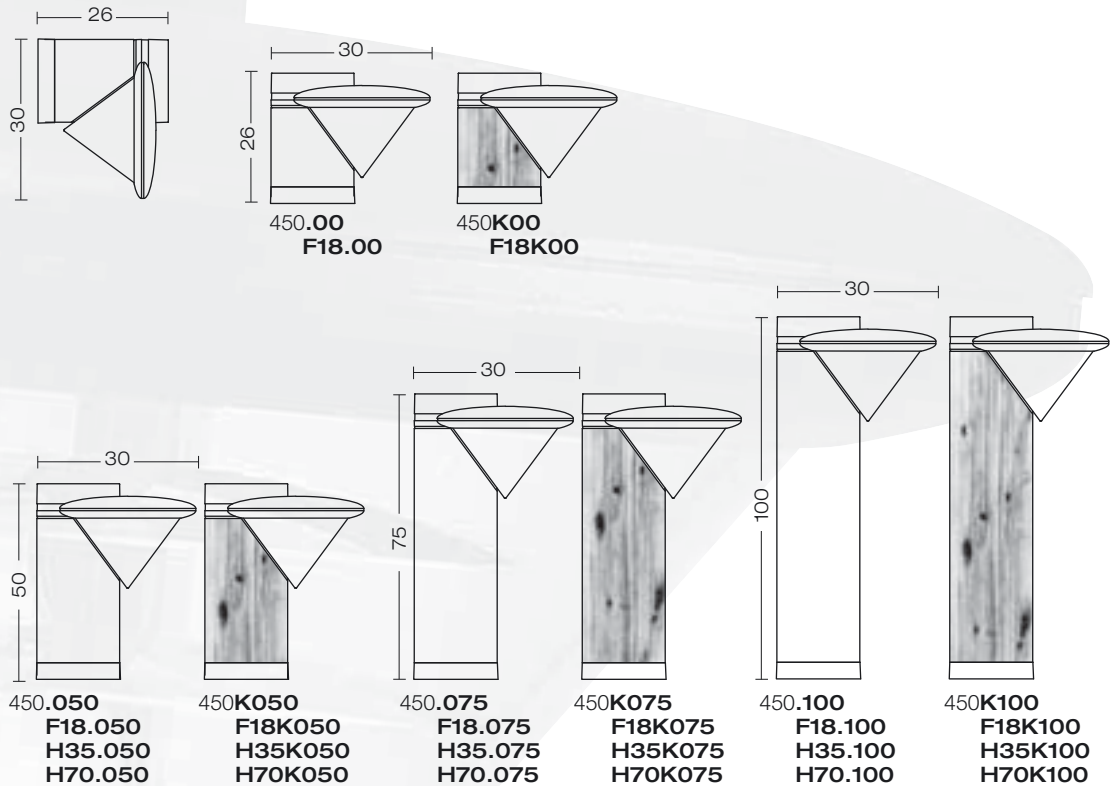

Electrification and Anchor Bolt for:

450H35.050
450H35.075
450H35.100
450H70.050
450H70.075
450H70.100

450H35K050
450H35K075
450H35K100
450H70K050
450H70K075
450H70K100

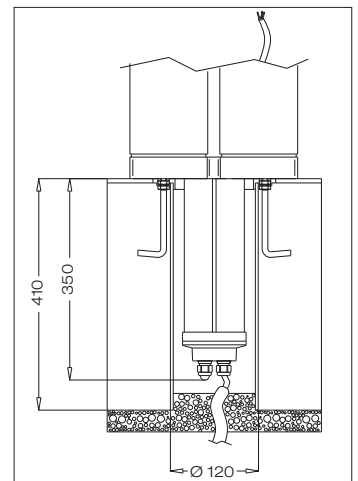

For technical details visit www.landa.it



FINISHING

K
dettagli / details
details / detalles
details:
page 12



Wood that isn't wood

Processo produttivo non inquinante
Production process is not polluting
C'est un procédé productif non polluant
Proceso productivo no contaminante
Chemierückstand und Abwasser

COLOURS

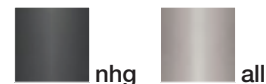

Accessories:

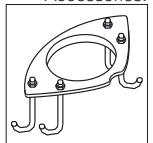

Anchor Bolt
code 00A450

ELECTRIFICATION

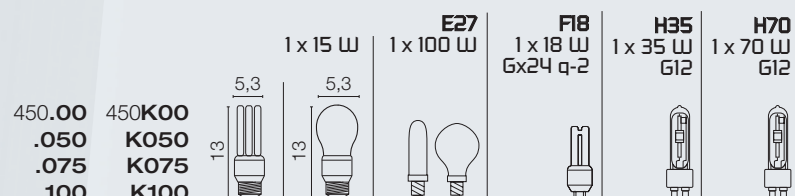



ibis

